

TECLES ELÉCTRICOS

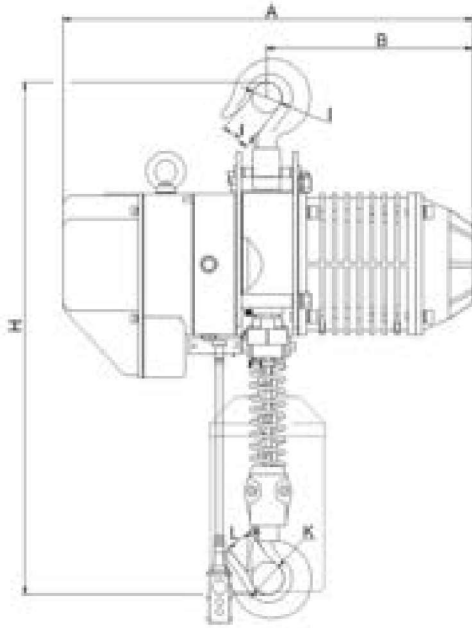
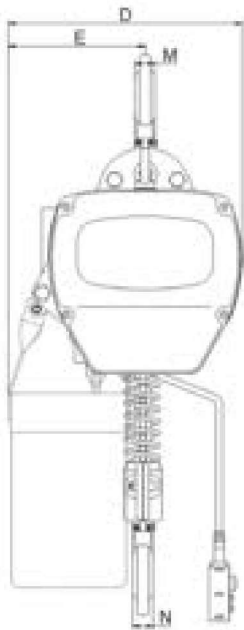

Tecles eléctricos industriales con gancho 380V SUMINATO

| SKU | Capacidad (ton) | Clasificación (FEM/ISO) | Duty Rating (ED) | Velocidad de levante (m/min) | Motor (Kw) | Dimensión cadena de carga (mm) | Caída cadena de carga | Peso neto kg (4m de cadena de carga) |
|--------|-----------------|-------------------------|------------------|------------------------------|------------|--------------------------------|-----------------------|--------------------------------------|
| 888000 | 0.5 | 1Am/M4 | 30% | 7.8 | 0.75 | 6.3 | 1 | 45 |
| 888001 | 1 | 1Am/M4 | 30% | 6.8 | 1.5 | 7.1 | 1 | 65 |
| 888002 | 2 | 1Am/M4 | 30% | 6.8 | 3.0 | 10.0 | 1 | 115 |
| 888003 | 3 | 1Am/M4 | 30% | 5.6 | 3.0 | 11.2 | 1 | 116 |
| 888005 | 5 | 1Am/M4 | 30% | 2.8 | 3.0 | 11.2 | 2 | 145 |

| SKU | Capacidad (ton) | Unidad (mm) | | | | | | | | | | |
|--------|-----------------|-------------|-----|-----|-----|-----|----|----|----|----|----|----|
| | | H | A | B | D | E | I | J | K | L | M | N |
| 888000 | 0.5 | 550 | 460 | 230 | 280 | 160 | 32 | 25 | 35 | 25 | 17 | 17 |
| 888001 | 1 | 600 | 520 | 260 | 300 | 176 | 40 | 31 | 40 | 31 | 24 | 24 |
| 888002 | 2 | 800 | 620 | 310 | 430 | 265 | 49 | 35 | 49 | 35 | 30 | 30 |
| 888003 | 3 | 845 | 620 | 310 | 430 | 265 | 59 | 42 | 59 | 42 | 35 | 35 |
| 888005 | 5 | 1030 | 620 | 310 | 430 | 325 | 60 | 45 | 60 | 45 | 43 | 43 |